

# Extended Noise Figure Data for the MAX2118 Satellite Tuner

*This application note presents extended noise figure data for the MAX2118 satellite tuner. This data is intended to supplement the MAX2118 data sheet. Noise figure and gain data are presented with more detail in the typical operating area of the device.*

## Introduction

The MAX2116/MAX2118 family of low-cost direct-conversion tuner ICs is designed for use in digital direct broadcast satellite (DBS) television applications, professional VSAT (very small aperture terminal) systems, and two-way "Internet-through-satellite" applications. The devices directly convert L-band signals to baseband using a broadband I/Q downconverter. The operating frequency range extends from 925MHz to 2175MHz.

Each IC includes an LNA with gain control, I and Q downconverting mixers, baseband lowpass filters, and gain and cutoff frequency control. Together, the RF and baseband variable gain amplifiers provide more than 79dB of gain control range.

The devices include fully monolithic VCOs and a complete frequency synthesizer. Synthesizer programming and device configuration are accomplished with a 2-wire serial interface. The MAX2116/MAX2118 devices are the most versatile family of DBS products available. With both single-ended and differential baseband outputs, these devices are compatible with virtually all QPSK/8-PSK demodulators. The tuners are available in a very small 40-pin QFN package.

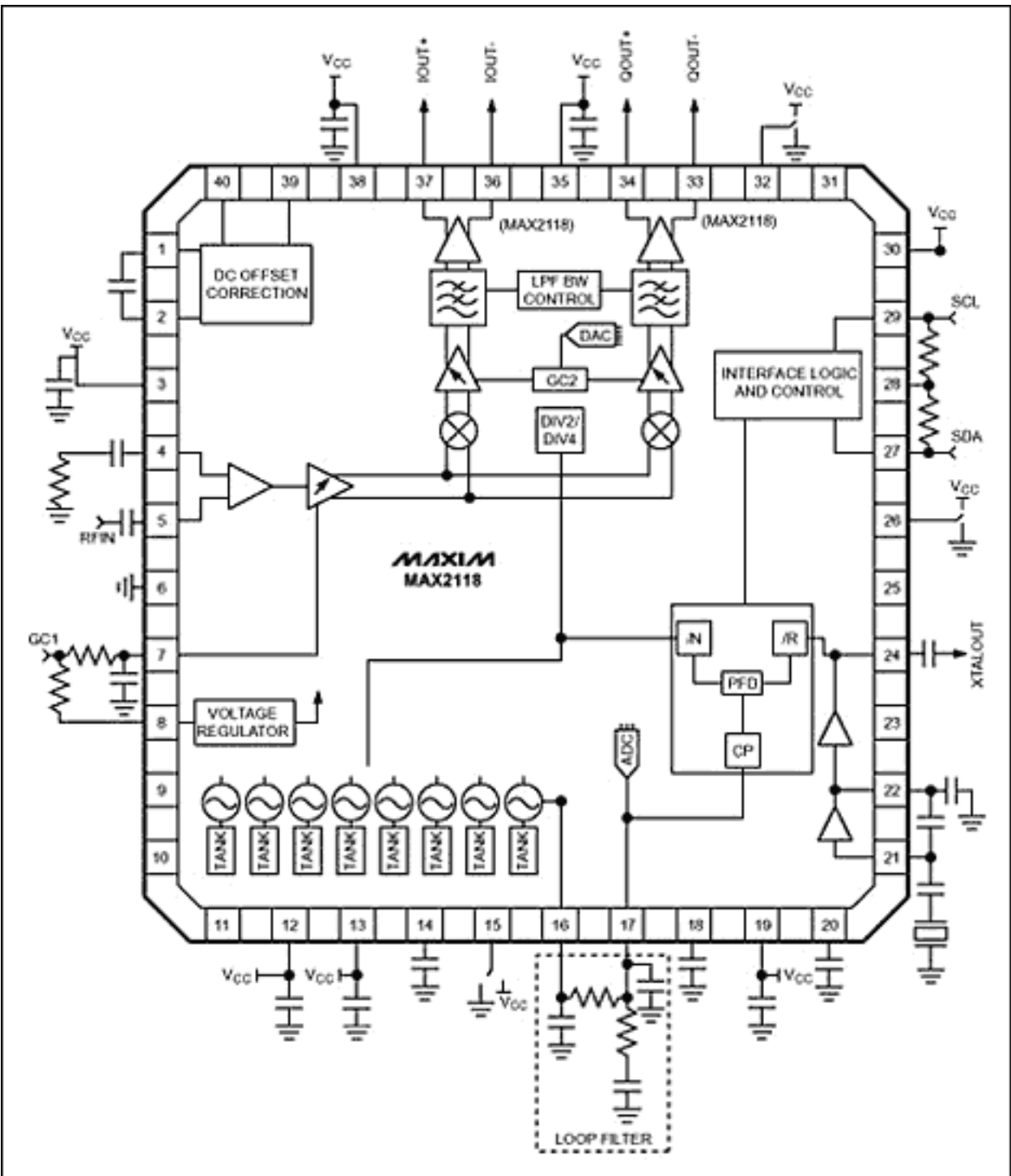

Figure 1. Typical Operating Circuit.

## Operational Overview

Figure 1 shows a typical operating circuit for the MAX2118. Pins 4 and 5 are the differential RF input. The RF front end will dominate the system noise figure. At low input signal levels, system noise figure will limit the Carrier to Noise Ratio (C/N) of the tuner. At large input signal levels, the output amplifiers will limit C/N due to linearity.

Pin 7 (GC1) is the variable gain control for the RF front end. The gain control line is typically controlled by a filtered PWM signal. A base band demodulator IC generates the PWM signal. In

a closed loop system the filtered PWM output will control gain to provide a constant amplitude signal on the MAX2118's IQ output.

Pins 36,37 and pins 33,34 on the MAX2118 are the differential I/Q outputs. The differential output amplifier gain can be set to deliver 590mVp-p differential or 1Vp-p differential on the output. The "DL" bit in the control register toggles the output amplifier gain setting. When DL=1 an additional 4.58dB of gain is added to the output amplifier. Setting the DL=1 is often used to improve linearity of the system. In a closed loop system when there is an additional 4.58dB of gain on the output amplifier the front-end gain is reduced by 4.58dB.

After the mixer there is a variable-gain baseband amplifier. This amplifier's gain is set by register GC2. GC2 is adjustable from 0 to 31 (decimal). The variable-gain baseband amplifier has a gain range of 24dB.

System noise figure is determined almost exclusively by the RF front-end gain. The GC1 voltage sets RF front-end gain. Noise figure is therefore set by GC1 voltage. Figure 2 shows this relationship.

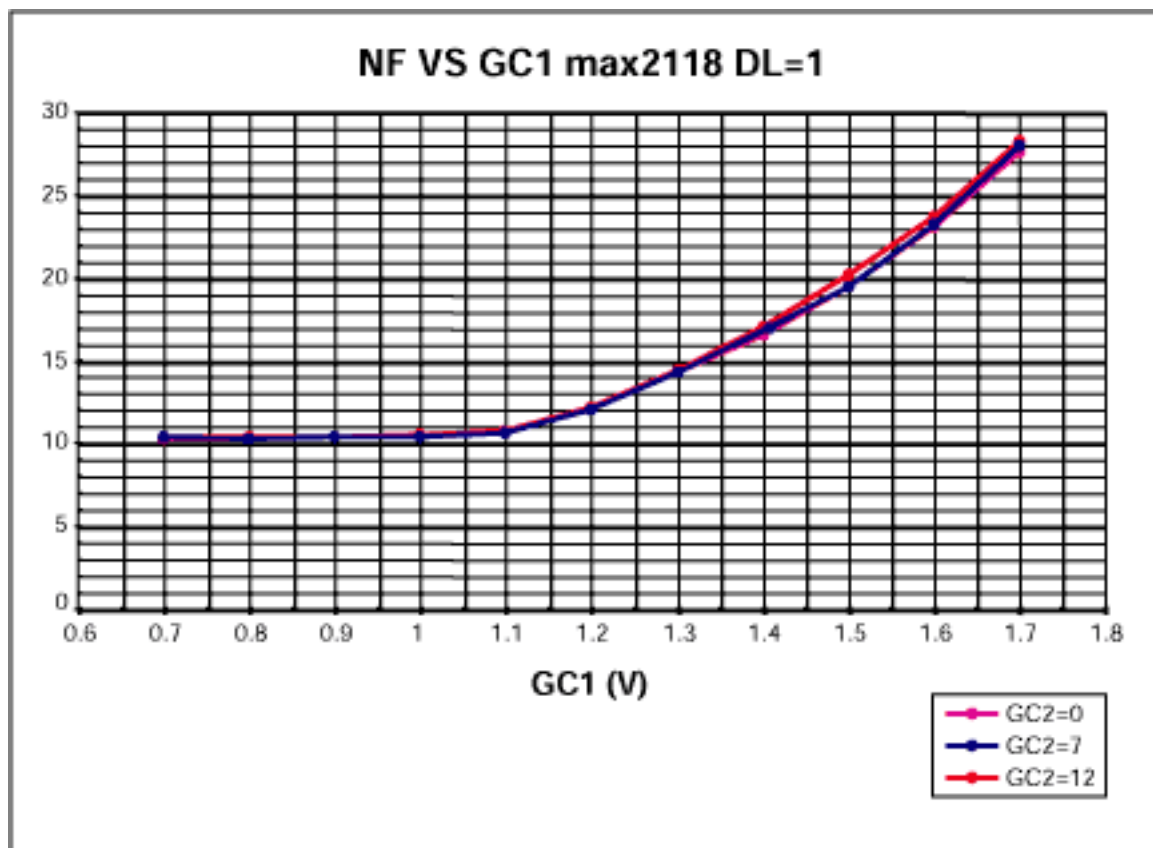

Figure 2. Noise Figure VS Gain Control Voltage.

In figure 2 the back end gain was varied by adjusting GC2. Observation of figure 2 shows that noise figure is approximately constant for a given GC1 voltage.

## Extended Noise Figure Data

Extended Noise figure data has been taken for the MAX2118. This data is used to configure the MAX2118 for optimal operation.

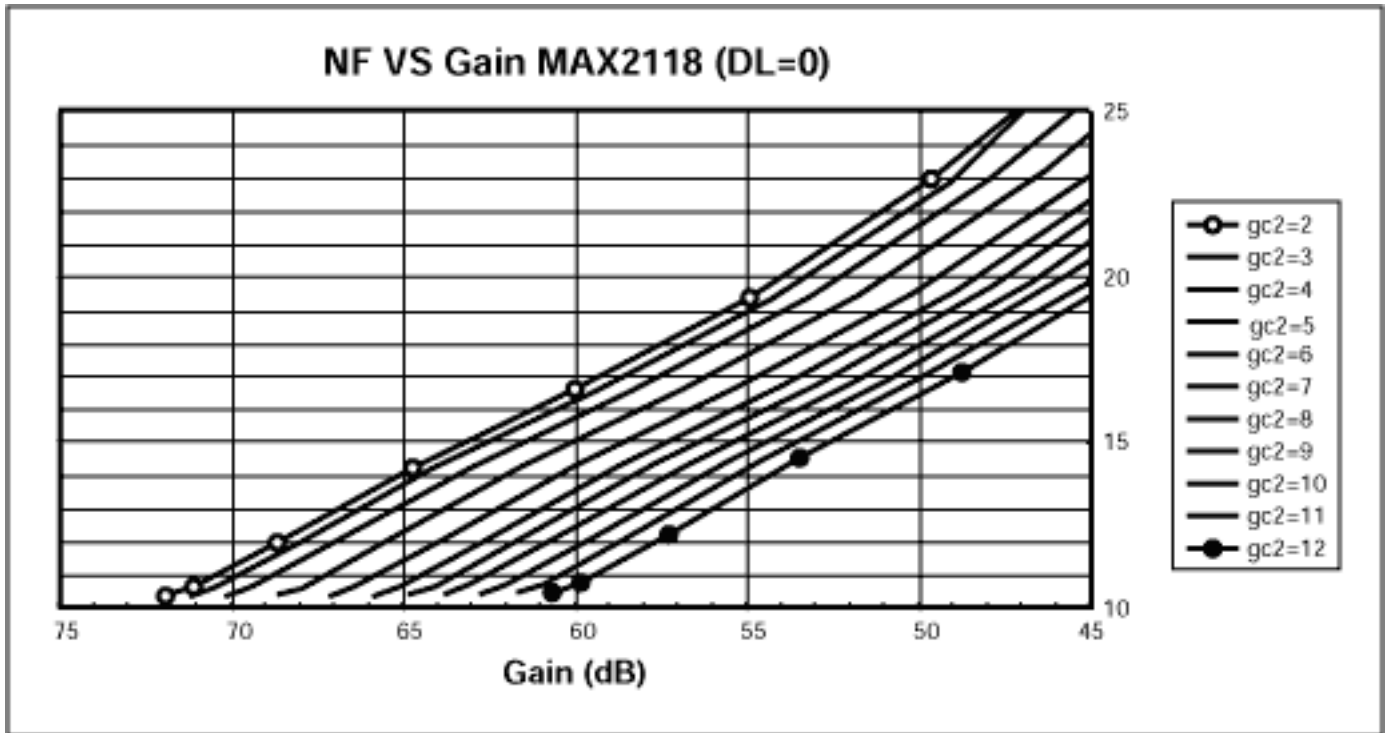

Figure 3. Noise Figure VS Gain and GC2 Setting (DL=0).

Figure 3 shows noise figure versus gain and GC2 setting. Use this chart to determine which GC2 setting will provide the desired gain and noise figure required.

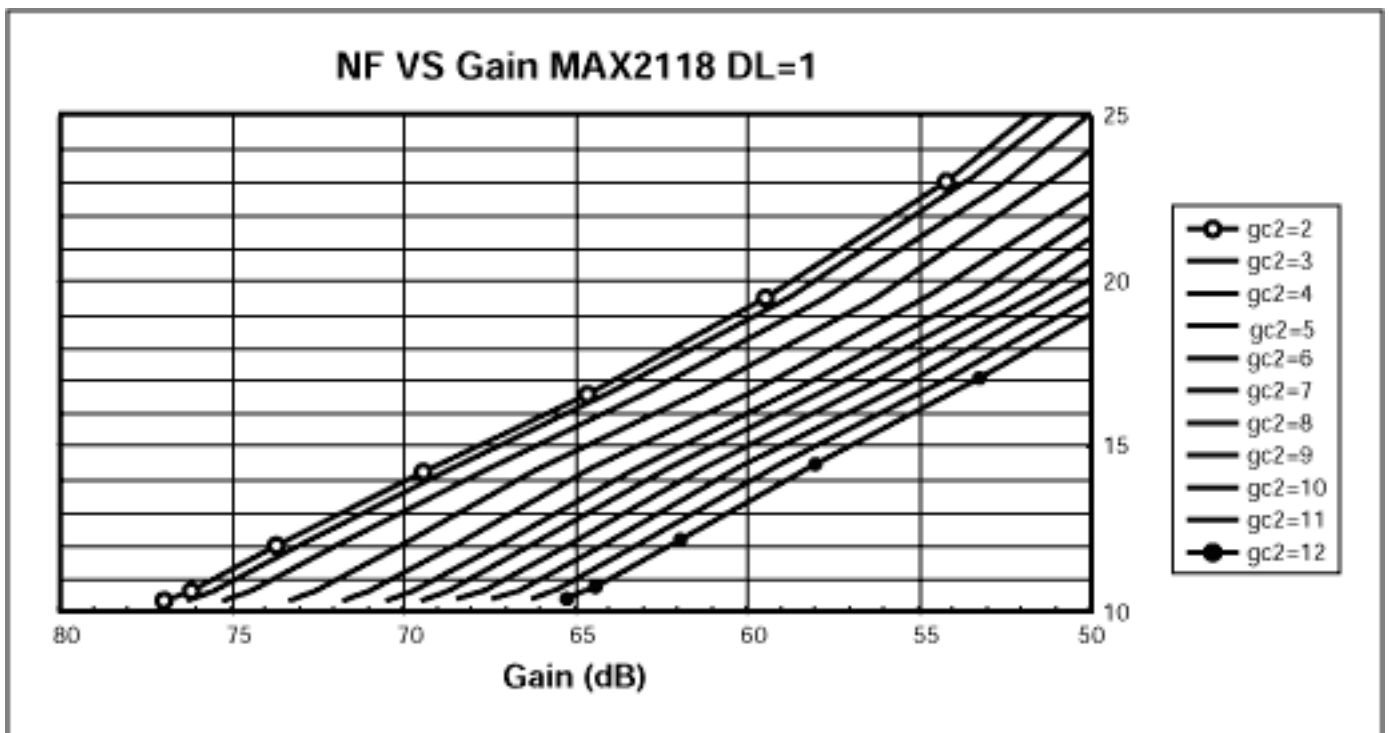

Figure 4. Noise Figure VS Gain and GC2 Setting (DL=1).

Figure 4 shows noise figure versus gain and GC2 setting. Use this chart to determine which GC2 setting will provide the desired gain and noise figure required.

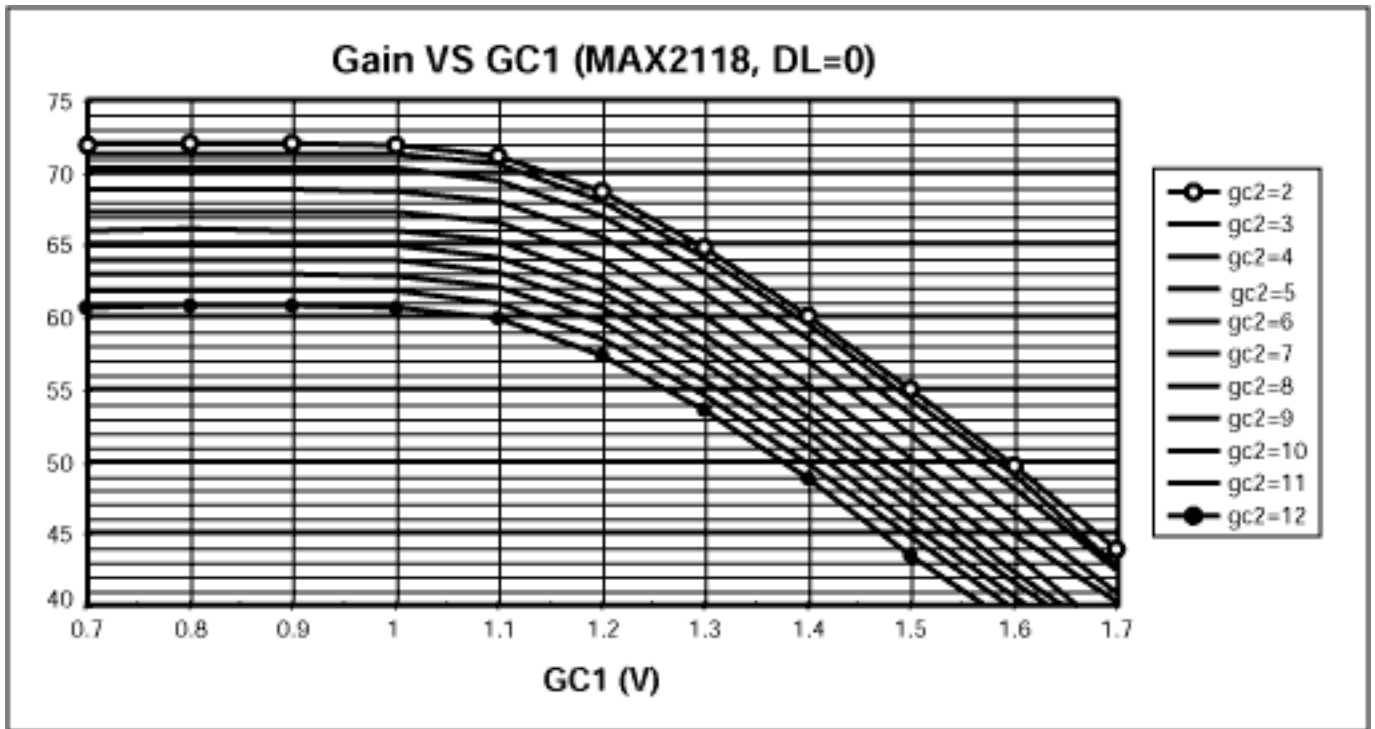

Figure 5. Gain VS Gain Control Voltage (GC1) for DL=0.

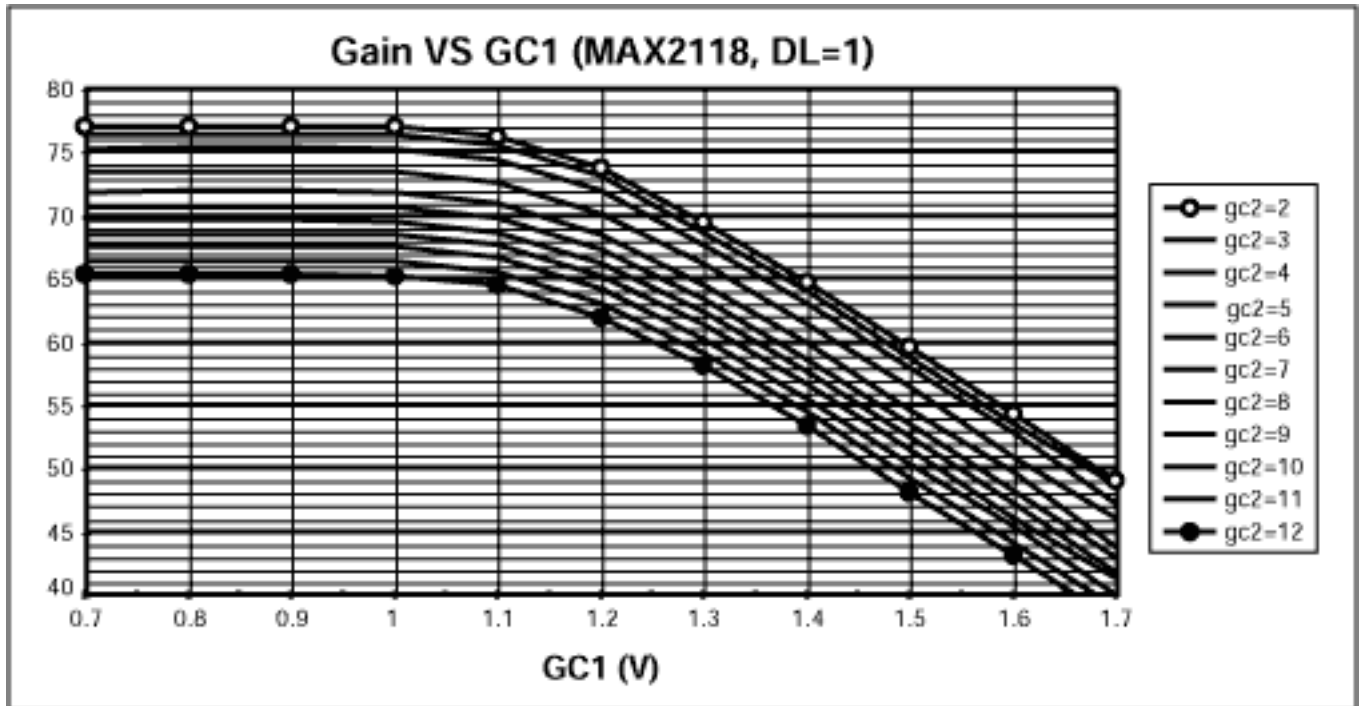

Figure 6. Gain VS Gain Control Voltage (GC1) for DL=1.

## Conclusion

This application note has presented extended noise figure data for the MAX2118. This data is

intended to supplement the MAX2118 data sheet. Noise figure and gain data are presented with more detail in the typical operating area of the device.

### **More Information**

MAX2116: [QuickView](#) -- [Full \(PDF\) Data Sheet](#)

MAX2118: [QuickView](#) -- [Full \(PDF\) Data Sheet](#)